

INSTRUCCIONES DE ARMADO / ASSEMBLY INSTRUCTIONS
CAJONERA HUNA / HUNA DRESSER



LOT N°

RTA[®]
m u e b l e s

Tel: (602) 695 9581 / 695 91 81 | EXT 118
La Nueva Estancia, Yumbo - Valle del Cauca - Colombia
www.rta.com.co

¡ATENCIÓN! / ATTENTION!

En las próximas páginas está el contenido de las piezas y herrajes del mueble. Asegúrate de que la cantidad de herrajes y piezas que hay en la caja sea la correcta y todo esté en buen estado. Ya que cuando el mueble esté armado no podrás realizar ninguna reposición.

On the next pages is the content of the pieces and hardware of the furniture.

Make sure the number of hardware and parts in the box is correct and everything is in good condition. When the furniture is assembled you will not be able to make any replacement

Recomendaciones Importantes / Key Recommendations

- Ensamble el mueble entre dos personas. / Assemble the cabinet between two people.
- Ensamble el mueble sobre una superficie plana y lisa, preferiblemente sobre un tapete o el cartón de la caja. / Assemble the cabinet on a flat smooth surface, preferably on a carpeted floor or the box carton.
- Se recomienda utilizar un destornillador eléctrico para facilitar el ensamble / It is recommended to use an electric screwdriver to facilitate assembly.

Herramientas Necesarias / Required Tools



Destornillador de estrella
Phillips Head
Screwdriver



Destornillador de pala
Flat Head
Screwdriver

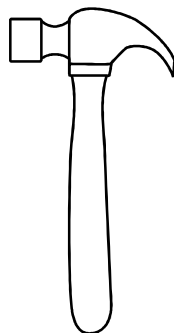

Martillo
Hammer

Herrajes Básicos / Basic Hardware

Aplica estas instrucciones cada vez que vayas a utilizar uno de estos herrajes durante el armado. / Apply these instructions everytime you're using one of these connectors during the assembly.

Tarugos / Wood Dowels

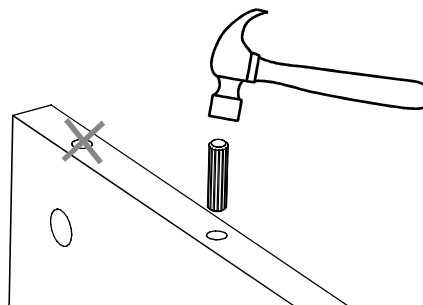

1. Inserta el tarugo en la perforación indicada y golpéalo suavemente hasta que llegue hasta el final de la perforación. / Put in the dowel inside the indicated hole and softly hit it until it's fully inside.

2. Verifica que NO se inserte el tarugo en la perforación de la caja minifix. / Verify that the dowel is NOT inserted into the perforation of the minifix cam.

Minifix y Pernos / Minifix Cam & Spreading Bolt

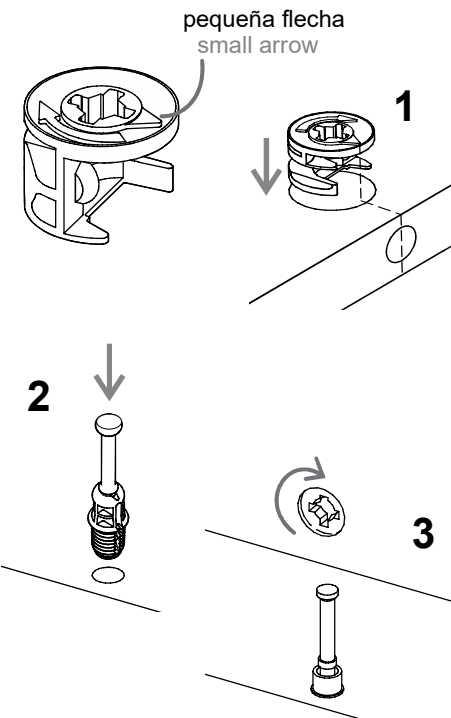



1. La caja minifix tiene una pequeña flecha en su parte superior, se debe insertar las cajas minifix con la flecha apuntando hacia la perforación que hay en el borde de la pieza. / The Minifix cam has a little arrow on its upper surface you should insert these cams with the little arrow pointing towards the drilling on the panel's edge.

2. Se debe insertar el perno con la parte plástica hacia abajo. / The spreading bolt should be put with the black plastic part facing down.

3. Luego de unir las piezas, se deben girar 180° las cajas minifix con un destornillador de estrella para ajustar y asegurar el ensamble. / After joining two panels together you should turn the cams 180° with a phillips head screwdriver to adjust and secure the joint.

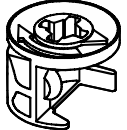
Herrajes / Hardware

 <p>Herraje unión esquinas / Corners bracket</p> <p>x2</p>	 <p>Kit Antivuelco + Tornillos / Wall Fixing Kit + Screws</p> <p>x2</p>	 <p>Manija / Handle</p> <p>x6</p>	 <p>Caja Minifix / Minifix Cam</p> <p>x31</p>
 <p>Pata de Acero / Steel legs</p> <p>x4</p>	 <p>Perfil H / H Profile</p> <p>x1</p>	 <p>Perno Minifix / Spreading bolt</p> <p>x31</p>	 <p>Puntilla / nail</p> <p>x30</p>
 <p>Rieles + tornillos / Slides + screws</p> <p>x3</p>	 <p>Tapa Adhesiva Minifix / Cover Caps</p> <p>x5</p>	 <p>Tapa Adhesiva Minifix / Cover Caps</p> <p>x30</p>	 <p>Tarugo / Wood dowel</p> <p>x14</p>
 <p>Tornillo ensamble / Drywall screw</p> <p>x12</p>	 <p>Tornillo lámina / Flat head screw</p> <p>x20</p>		

Cargas Máximas / Max Suggested Loads

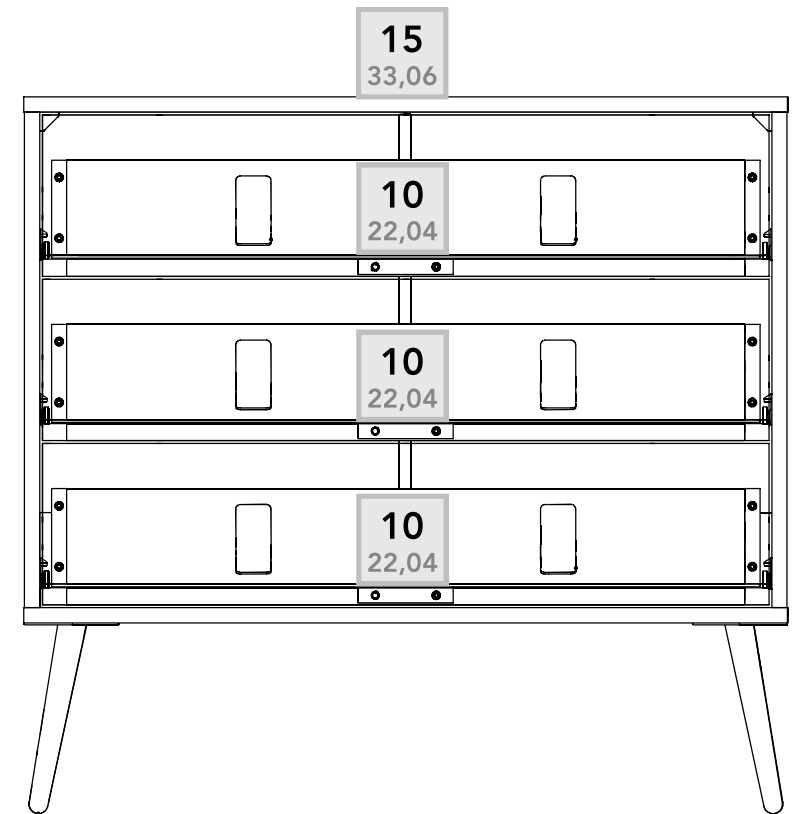

*Peso en Kg / Weight in Kg.

*Peso en Libras / Weight in Lb

Piezas de Armado / Assembly Parts

A - x1
B - x1
C - x1
D - x1
E - x3
F - x3
G - x3
H - x3
I - x3
J - x3
K - x2
L - x1

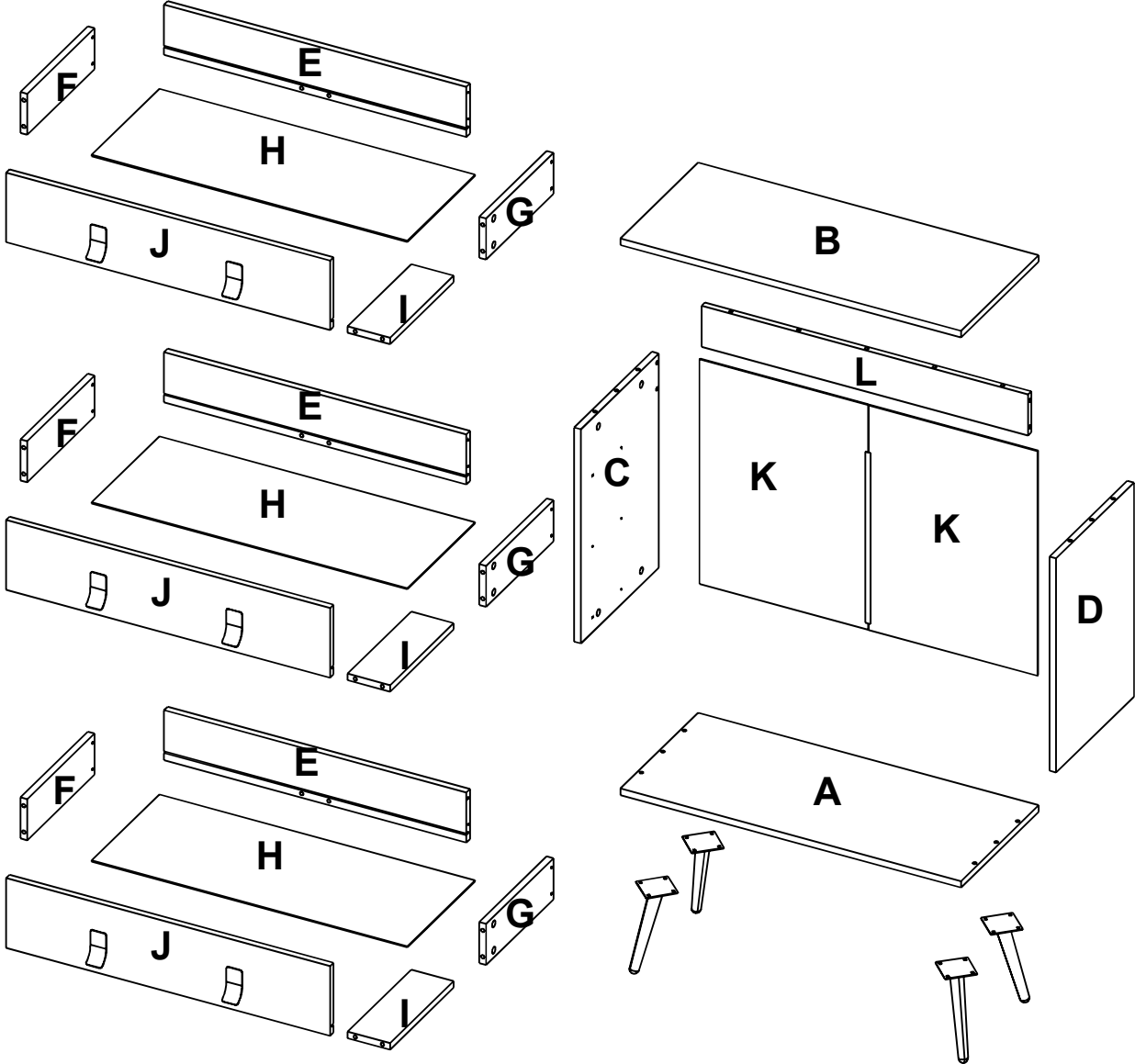

1

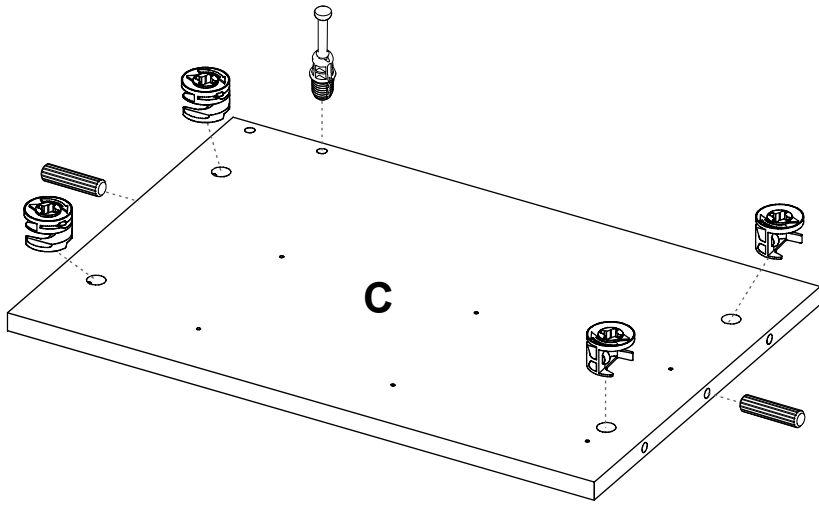

2

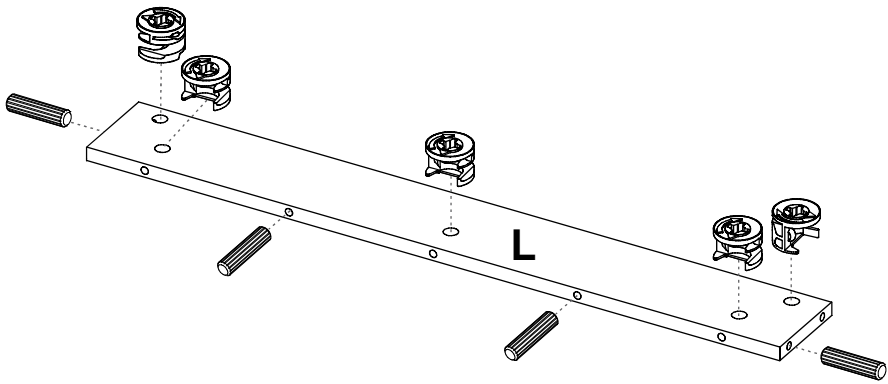

3

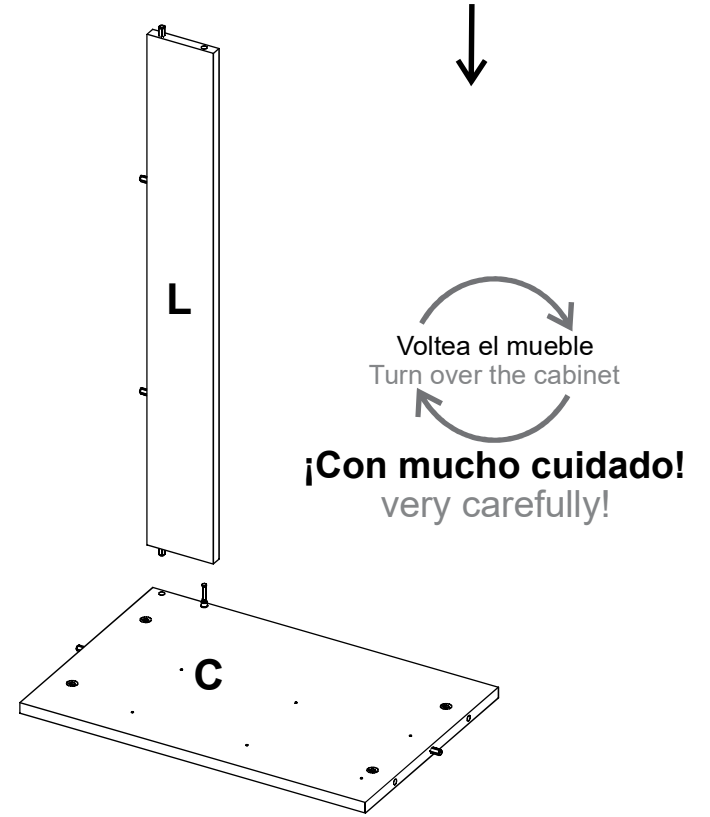

4

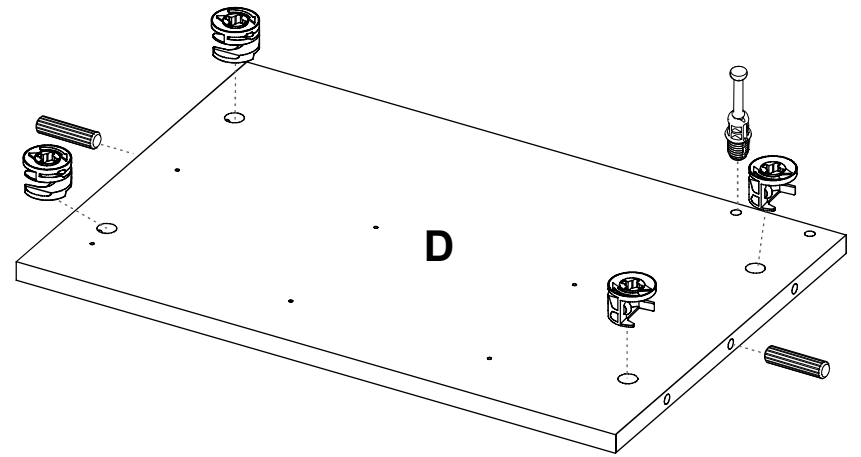

5

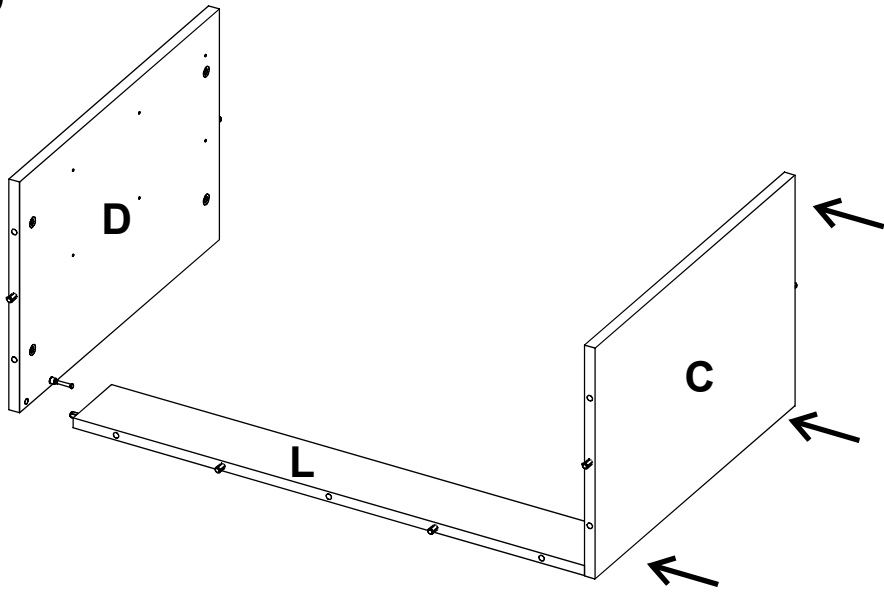

6

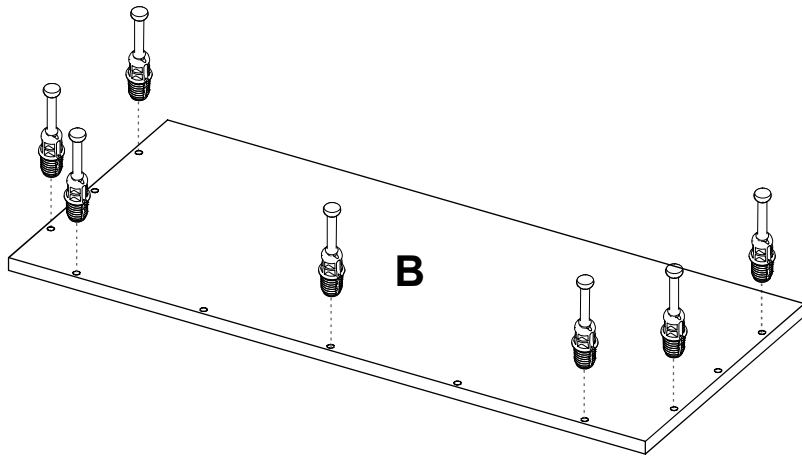

7

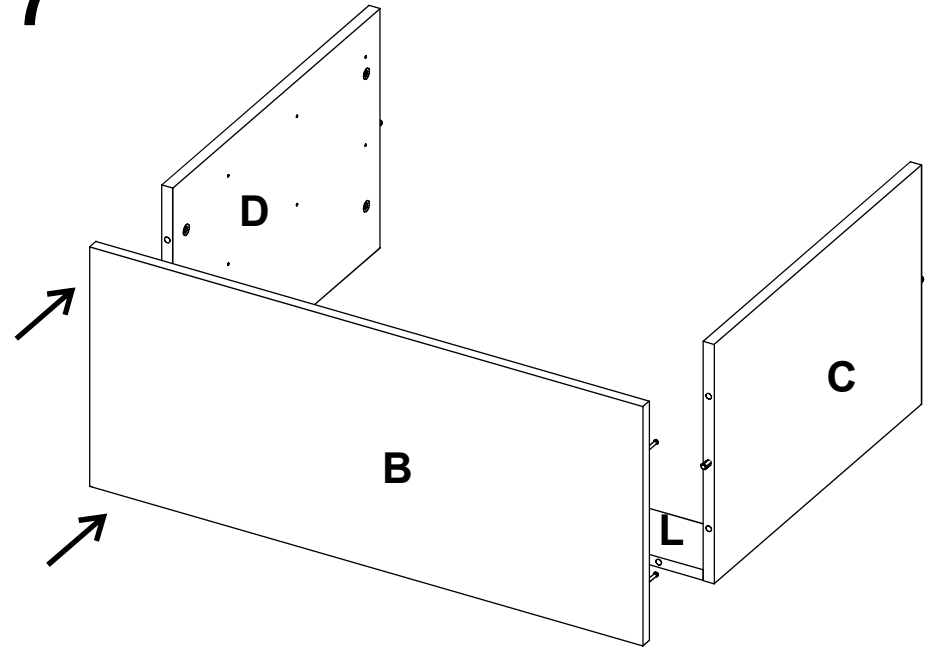

8

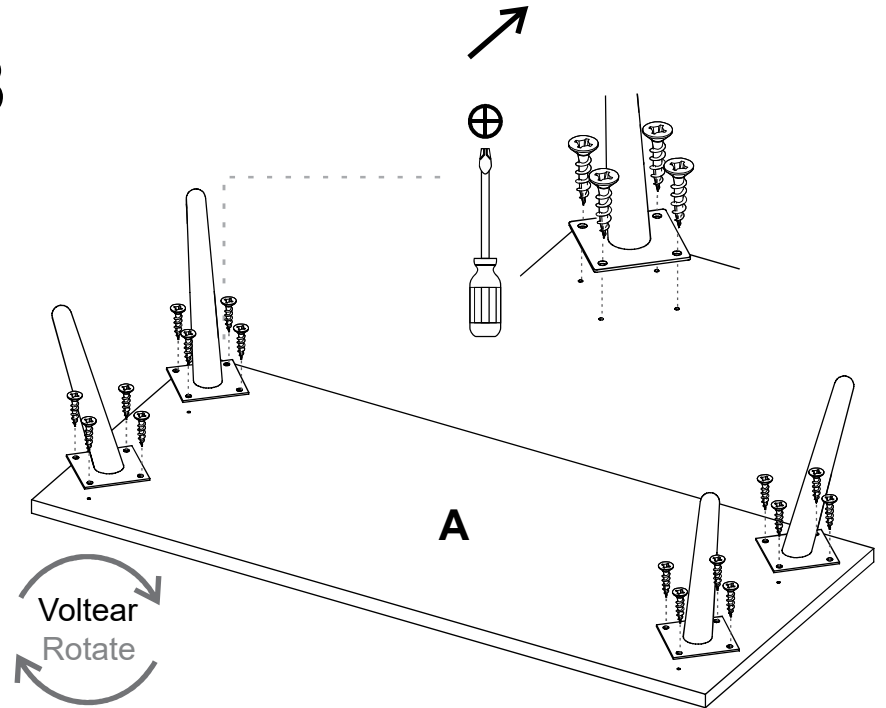

10

Instalación de los rieles Drawer slides installation

Instalación de los rieles

La rueda debe ir hacia la parte del frente de la pieza y hacia abajo, así:

Drawe installation

The wheel should go towards the front edge of the panel and facing down, like this:

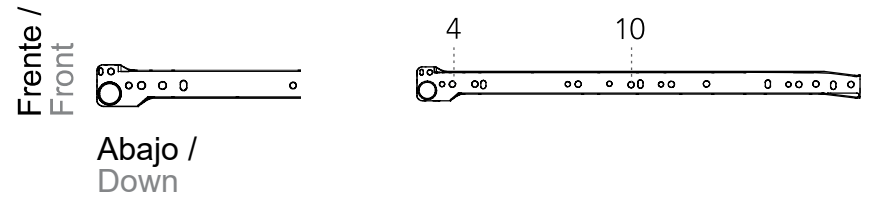

9

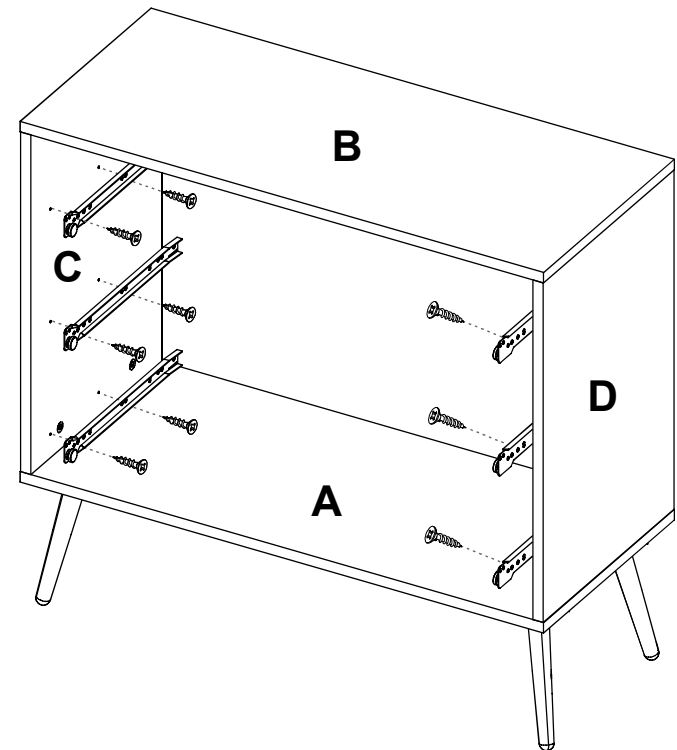
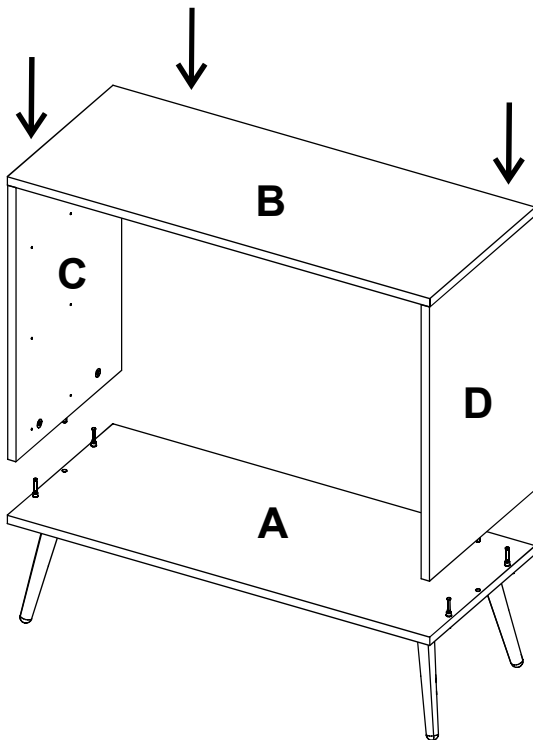
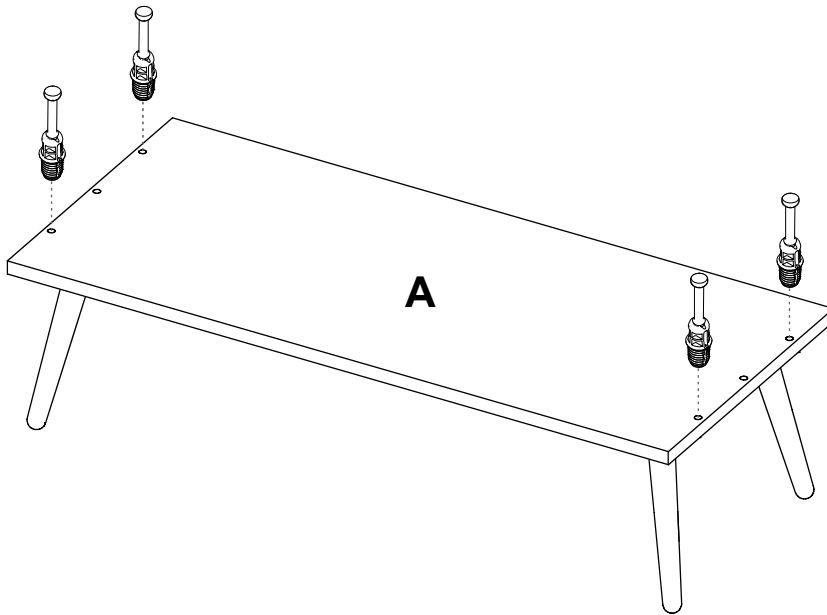

11

Ubicar los soportes esquineros en las esquinas y atornillar con tornillo lamina 9/16"

Place the corner supports in the corners and screw with flat head screw 9/16"

1

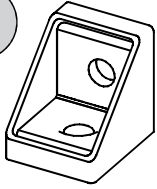

Soporte Esquinero
Corner Support

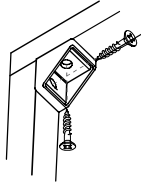

Tornillo lamina 9/16"
Flat head screw 9/16"



Tornillos lamina 9/16"
Flat head screws 9/16"

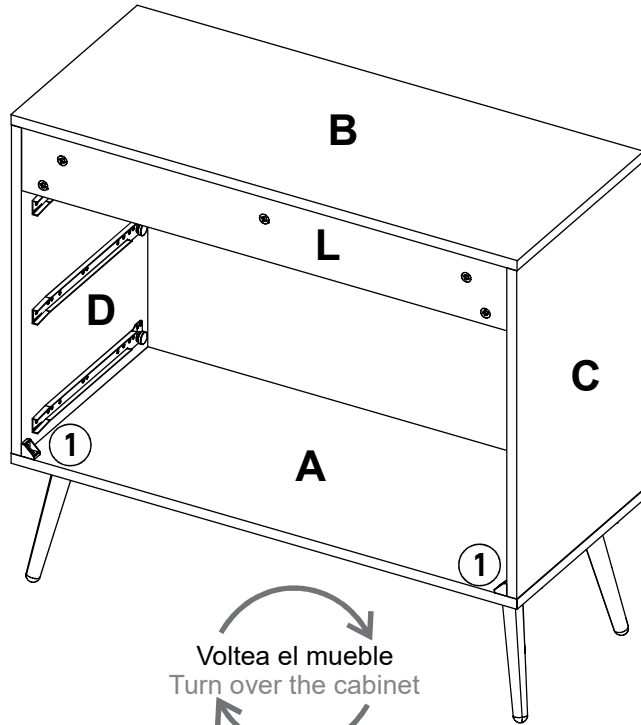

Voltea el mueble
Turn over the cabinet

¡Con mucho cuidado!
very carefully!

12

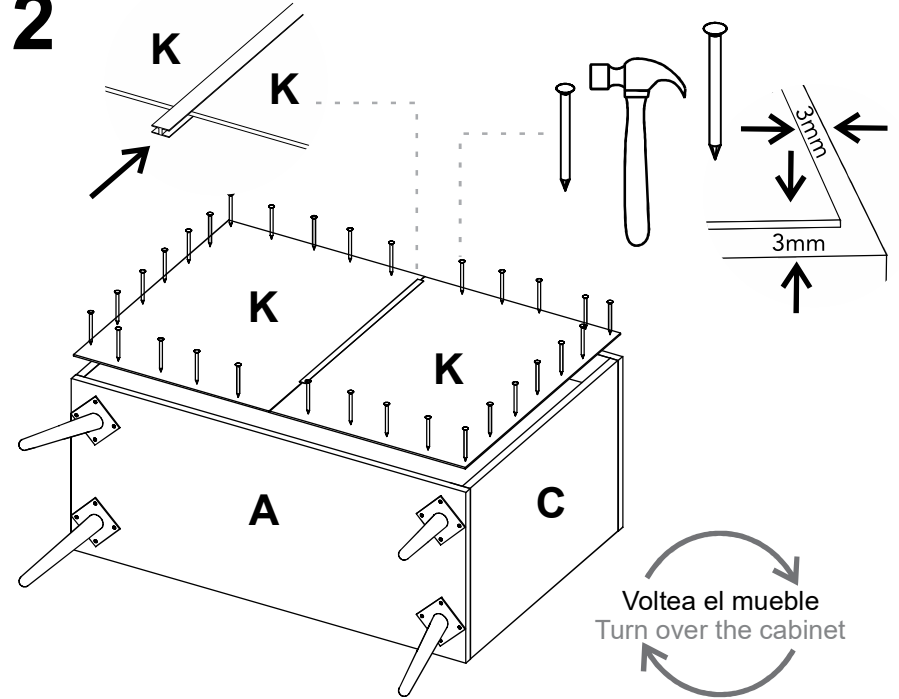

Voltea el mueble
Turn over the cabinet

¡Con mucho cuidado!
very carefully!

13

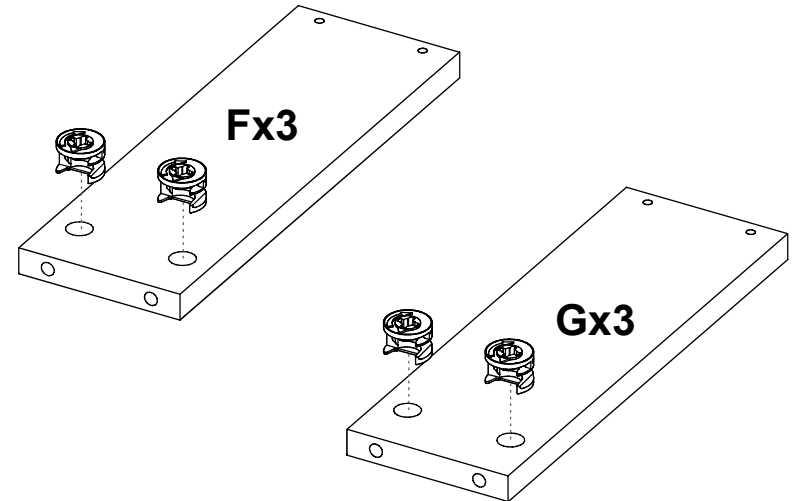

14

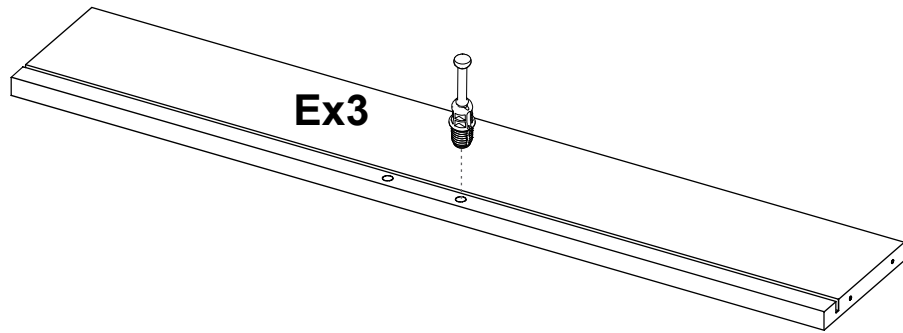

16X3

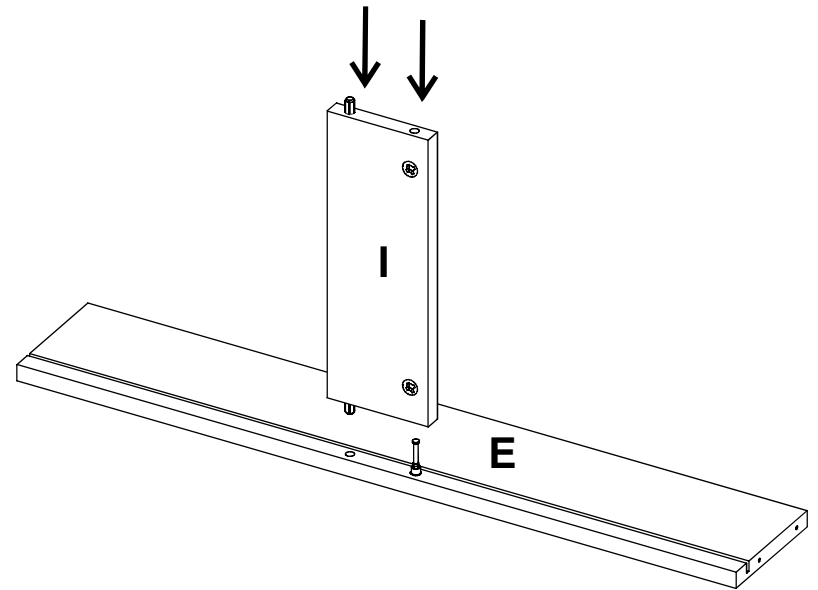

15

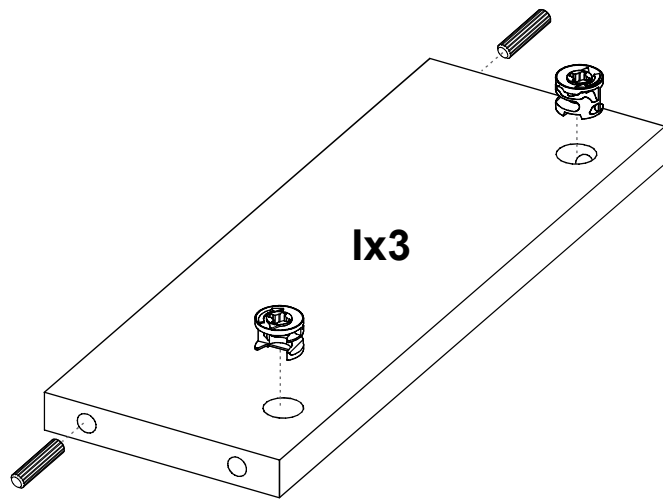

17X3

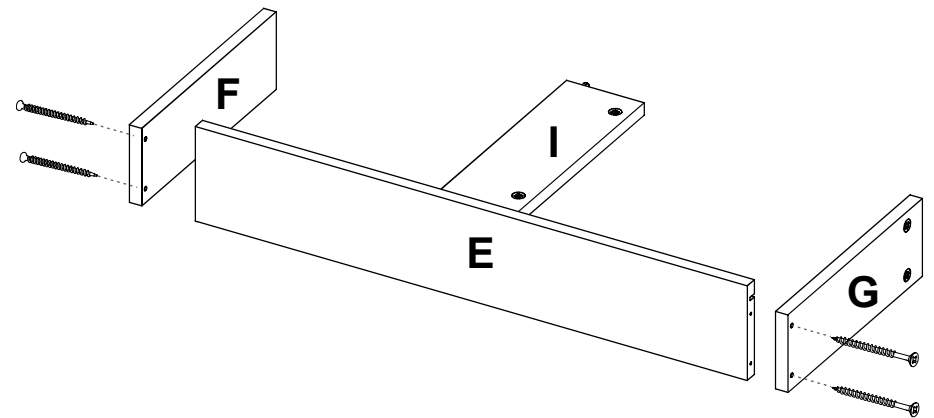

18X3

Desliza el fondo dentro de las ranuras.
Slide the back panel inside the grooves.

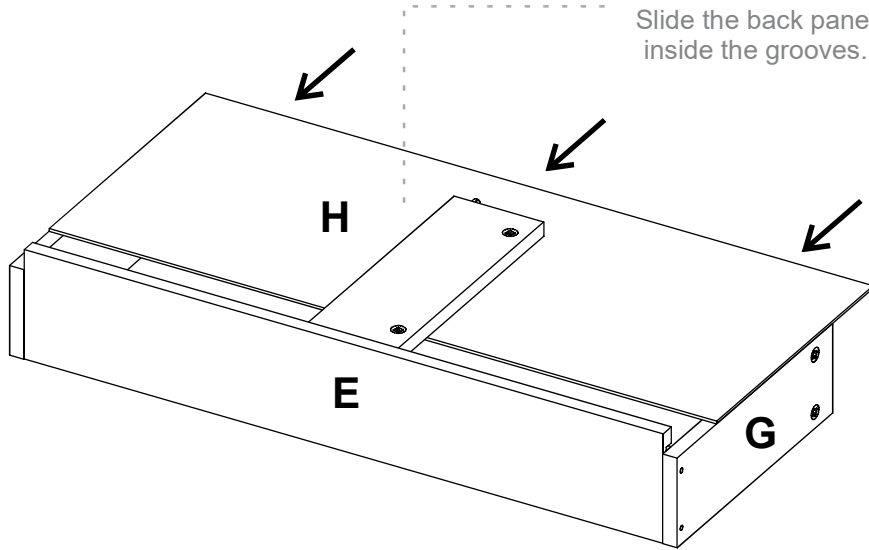

20X3

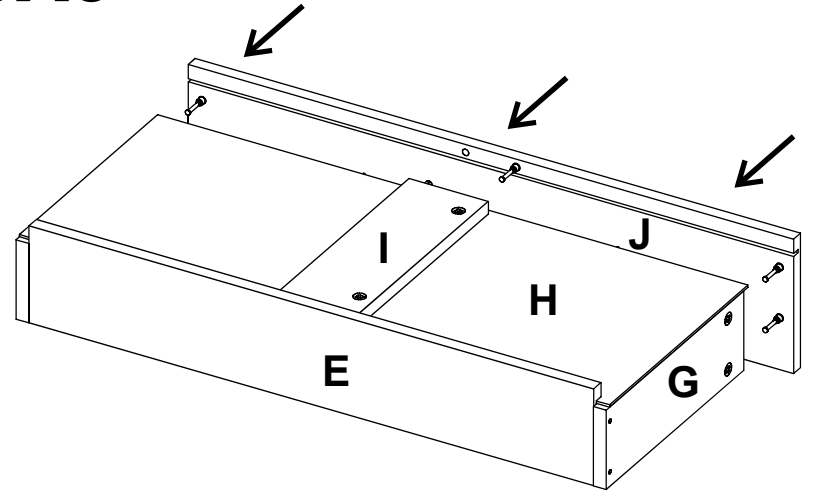

19

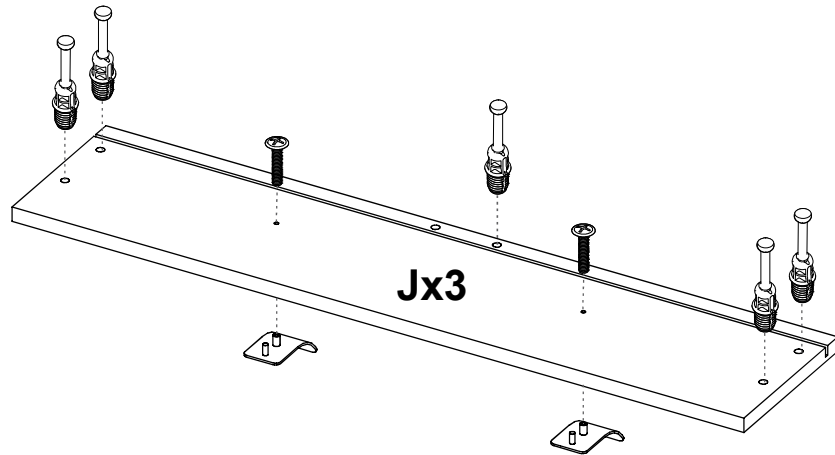

21X3

Instalación de los cajones Drawer Installation

La rueda del riel debe ir en la parte trasera del cajón.
The wheel should go on the rear part of the drawer.

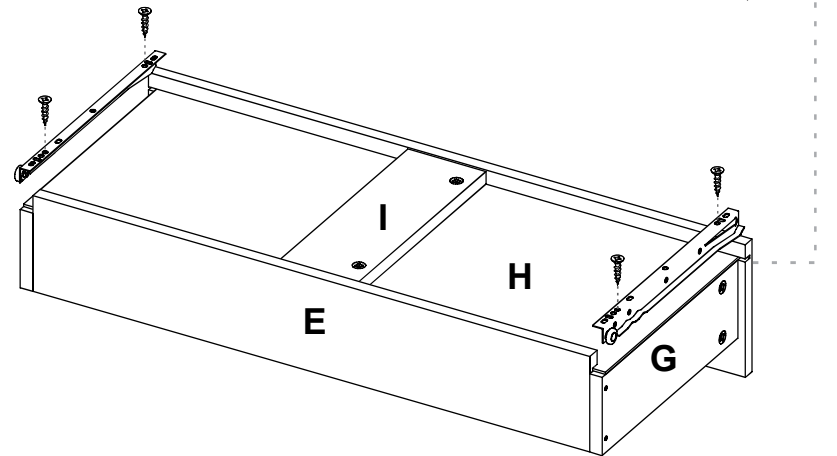
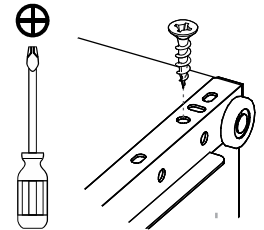

22

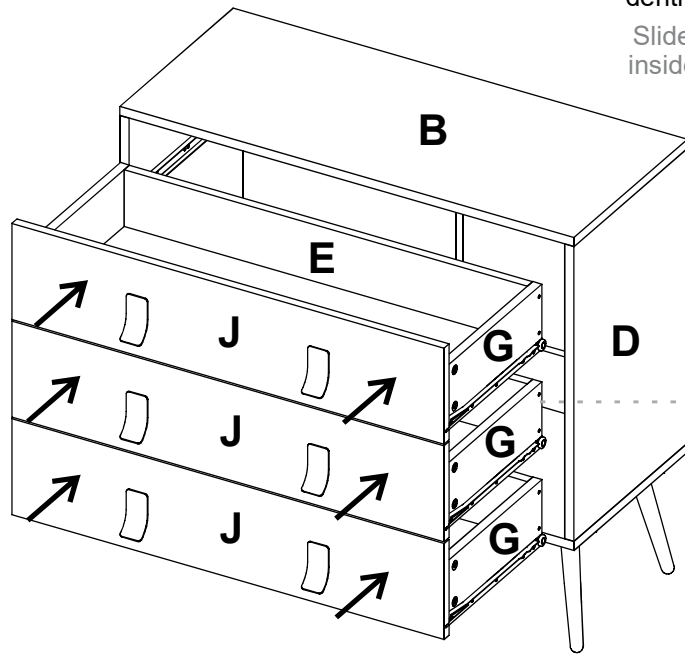

Desliza los cajones dentro del mueble.
Slide the drawers inside the cabinet.

23

Fija el mueble a la pared Fix your cabinet to the wall

- 1 Haz una perforación en el borde superior de la parte superior del mueble y fija un extremo de la correa con el tornillo de 15mm y una arandela.
Make a small hole on the top edge of the furniture top and fix one side of the strip with the 15mm screw and the washer. 
- 2 Extiende la correa y mide en la pared para perforar.
Stretch the strip and measure on the wall to drill. 
- 3 Perfora la pared a 30mm de profundidad con una broca de 6mm.
Drill a hole in your wall to a depth of 30mm using a 6mm drill bit. 
- 4 Inserta el chazo plástico en la perforación.
Insert the plastic wall anchor into the hole. 
- 5 Fija el otro extremo de la correa con la arandela y el tornillo que sobran.
Fix the other side of the strip with the screw and the washer. 

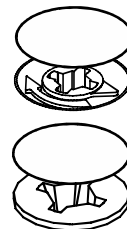
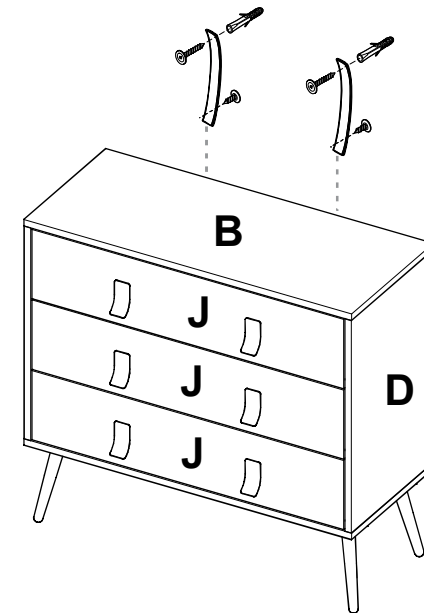

Después de ajustar todas las cajas minifix y los tornillos, cúbralas con las tapas adhesivas.
After you finish the adjustment of the cams and screws, cover them with the cover caps.

A

Al terminar de armar, desprenda las letras adhesivas.
After you finish assembling the cabinet, take off the adhesive letters.